

Optimized for DSI drilling

COP DS5 hydraulic rock drills offer high drilling rates in combination with low drill steel consumption. Steplessly variable rotation and high speed rotation capacity contribute to good drilling results.

Two main bodies with few numbers of moving parts

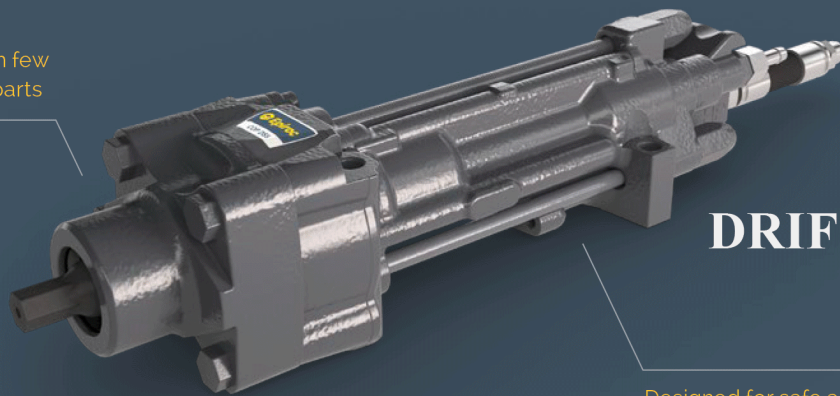

DRIFTER COPDS5

Designed for safe and reliable operation

+ Main benefits

Improved hole straightness due to optimized drilling speed at low feed force.

Long and slender piston matched to the drill steel, permits high impact energy to be utilized together with low drill steel stress.

Separate reversible rotation with stepless variable rotation speed.

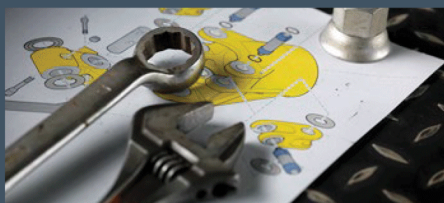

Installation instructions and retrofit support are available upon request.



Repair kit consisting of parts to be replaced during overhaul is available with quick delivery.



All spare parts and wear parts are available, with critical parts always in stock.

Technical specifications

Dimensions and weight

	COP DS5
Weight	45 kg (99.2 lb)
Length	709 mm (27.9 inch)
Width	218 mm (8.6 inch)
Height	142 mm (5.6 inch)
Height over drill center	70 mm (2.8 inch)

Impact ratings

	COP DS5
Impact power, max	5 kW (6.7 hp)
Impact rate, Hz	68 Hz
Hydraulic pressure	155 bar (2 248 psi)

Rotation ratings

	Rotation motor OMM 8/OMM 20
Max. drill rpm continuous	540 rpm/280 rpm
Max. drill torque continuous	40/90 Nm (29.5/66.4 lbf.ft)
Max. hyd pressure continuous	100 bar/100 bar (1450 psi/1450 psi)
Max. torque intermittent	54 Nm/126 Nm (39.8/92.9 lbf.ft)

Flushing and lubrication flow and pressure

	COP DS5
Flushing water pressure	4 bar (58 psi)
Flushing water consumption	0.25 l/s (0.53 cfm)
Flushing air pressure	2 bar (29 psi)
Lubricating air consump. at 2 bar	2.5 l/s (5.3 cfm)

Shank adapter

	COP DS5
Shank adapter	Hex. 22 mm x 108 mm (Hex (7/8)" x (4 1/4"))